

Swing Door Handle Set Installation Instructions



A Phillips screwdriver is required.

A 3mm hex wrench for set screws is provided in the hardware package.

To prevent damage to the handle set during the construction phase, use the enclosed construction handle to operate the door. Lift the handle to engage the multipoints. Push down to disengage.

Use water and a soft cloth to clean. Do not use brass cleaner or solvent based cleaning agents as they will remove the protective coating on the hardware.

Note: Handles and backplates vary by style but application is the same.

1. Apply the backplate gasket to the inside of the exterior and interior backplates. Push gaskets firmly into place to ensure a tight seal. Attach interior and exterior backplates to the door and fasten loosely with the screws provided. Note: The screw heads must be on the interior side of the door.
2. Insert the two-piece handle shaft into one handle. Be sure to orient the shaft as shown below. Screw the set screw until flush with handle using the hex wrench provided. Insert the handle with shaft attached through the escutcheon plate and door gear handle hole until extending out opposite side of door.
3. Install remaining handle onto shaft, pressing tightly to the backplates. Tighten the handle set screw with hex wrench. Screw until flush with handle.
4. Insert the keyed cylinder from the interior side of the door until it is flush with the exterior backplate. Install the cylinder screw in the screw hole below the deadbolt in the edge of the door to secure in place.
5. Hand tighten the backplate screws to complete assembly.

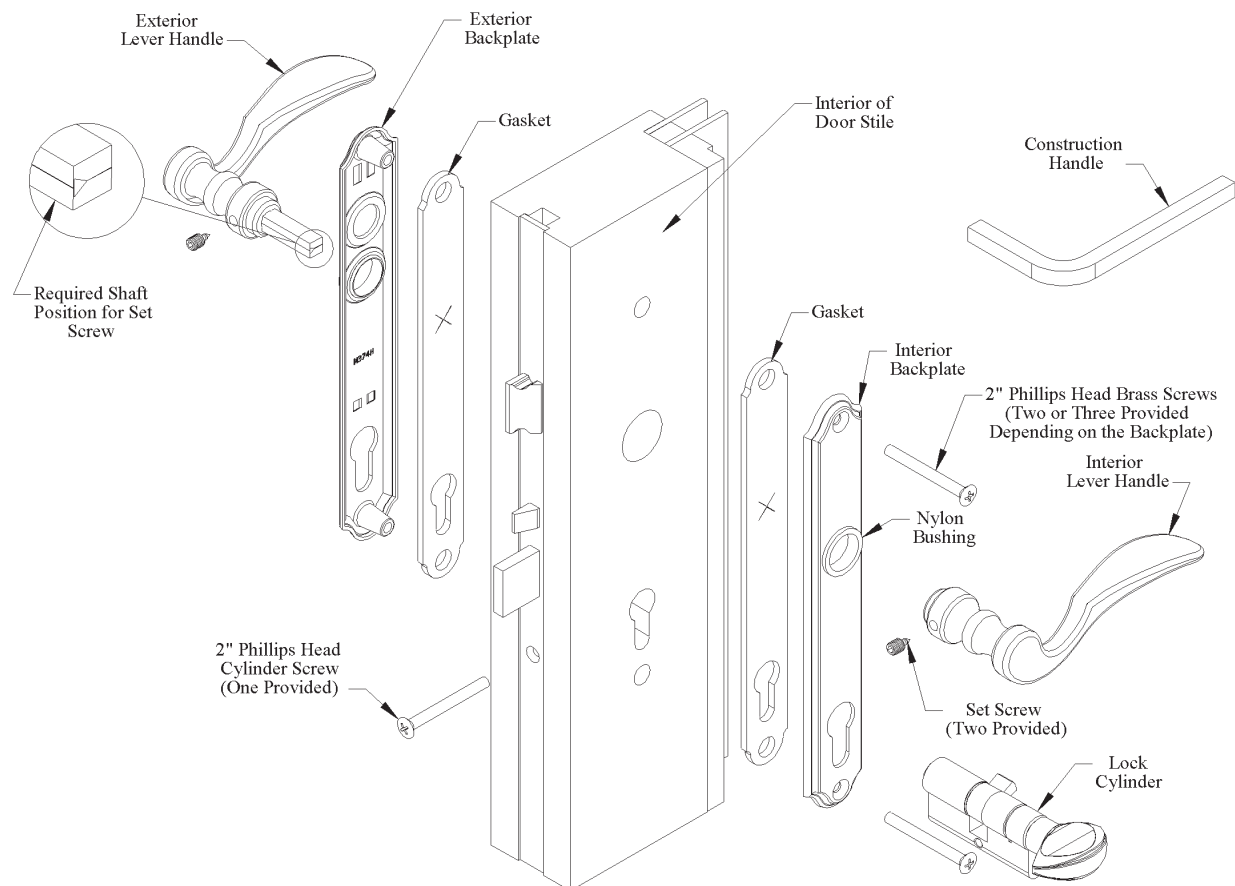

1-888-485-4885

www.us.hoppe.com

Fixed (Dummy) Trim Installation Instructions

Figure 1

1. Determine handing. Remember handles will be perpendicular to backplate, pointing either to the left or right.
2. Slide handle into backplate so square corners of the handle neck match up with notches in backplate.
3. Insert screw from back side of plate into handle neck and firmly tighten down with the included 6mm hex wrench.

Figure 2

1. For alternative backplate style, drill 1/8" pilot hole, then drill 7/16" hole through door stile to accept backplate screws and lugs. Make sure to drill straight through.
2. Mount handle and backplate assemblies to interior and exterior of door with screws provided.

A 6mm hex wrench is needed for installation

Note:

The inside backplate has through holes and the outside backplate has threaded lugs.

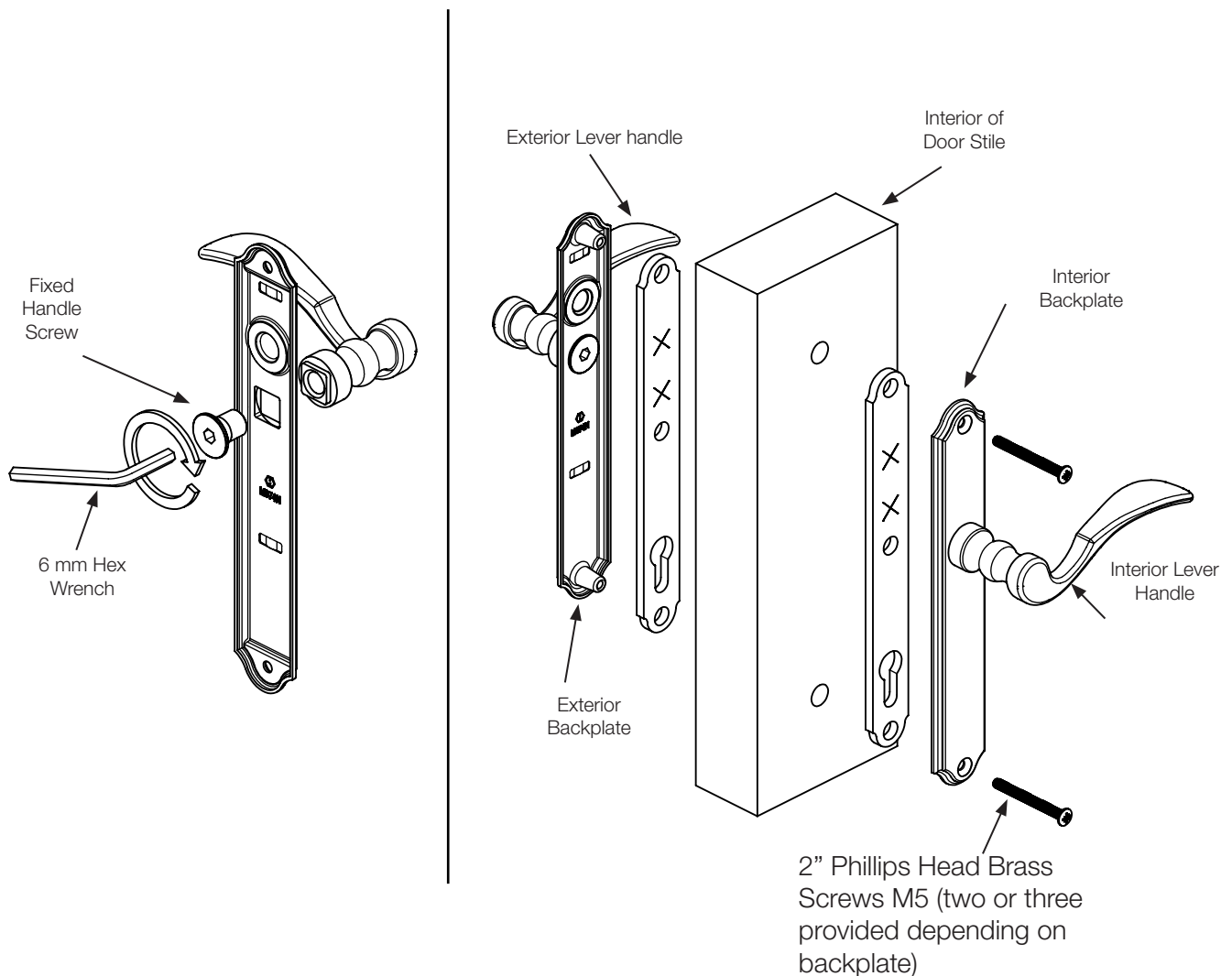

Installation Instructions

90-Degree Turn Cylinder

Tools required:

- Phillips head screw driver
- Hex wrench (provided)
- Ring wrench (provided)
- Pliers (recommended)

Installation:

1. Loosen set screw (C) on knob (D) using the hex wrench provided. Knob designs may vary from design shown.
2. Remove knob (D) from body of cylinder (B).
3. Align drive tab (J) with the cylinder body to install the cylinder into the lock as shown by (G). If the drive tab (J) cannot be rotated to this position, push the pin (E) down with the ring wrench (F) to disengage the stops and turn the cylinder shaft (B) until the drive tab (J) is aligned with the cylinder as shown by (G).
4. Holding in this position, insert the cylinder body into the lock so the drive tab (J) is inside of the lock.
5. Rotate the shaft (B) (use pliers if necessary) such that the top of the shaft (B) moves toward the edge of the door or insert the key (A) into the cylinder and rotate such that the top of the key (A) moves towards the edge of the door (H). The shaft or key will rotate freely and will stop after approximately 120°. Do not force rotation. The dead bolt should not extend (dead bolt will extend on single point gear). Confirm that one of the two set screw openings is positioned on the bottom of the shaft (B).

Warning: If the shaft (B) or key (A) is rotated the wrong direction, the cylinder will lock after approximately 120° and cannot be rotated in either direction. If this happens, push the pin (E) down with the ring wrench (F) included to disengage the stops and turn the shaft (B) or key (A) in the opposite direction until the dead bolt extends.

6. Fix knob (D) on shaft (B) as shown.
7. Tighten set screw (C). Install cylinder screw (K) as shown.

Removal:

1. Loosen and remove cylinder screw (K) and repeat steps 1-4 above.

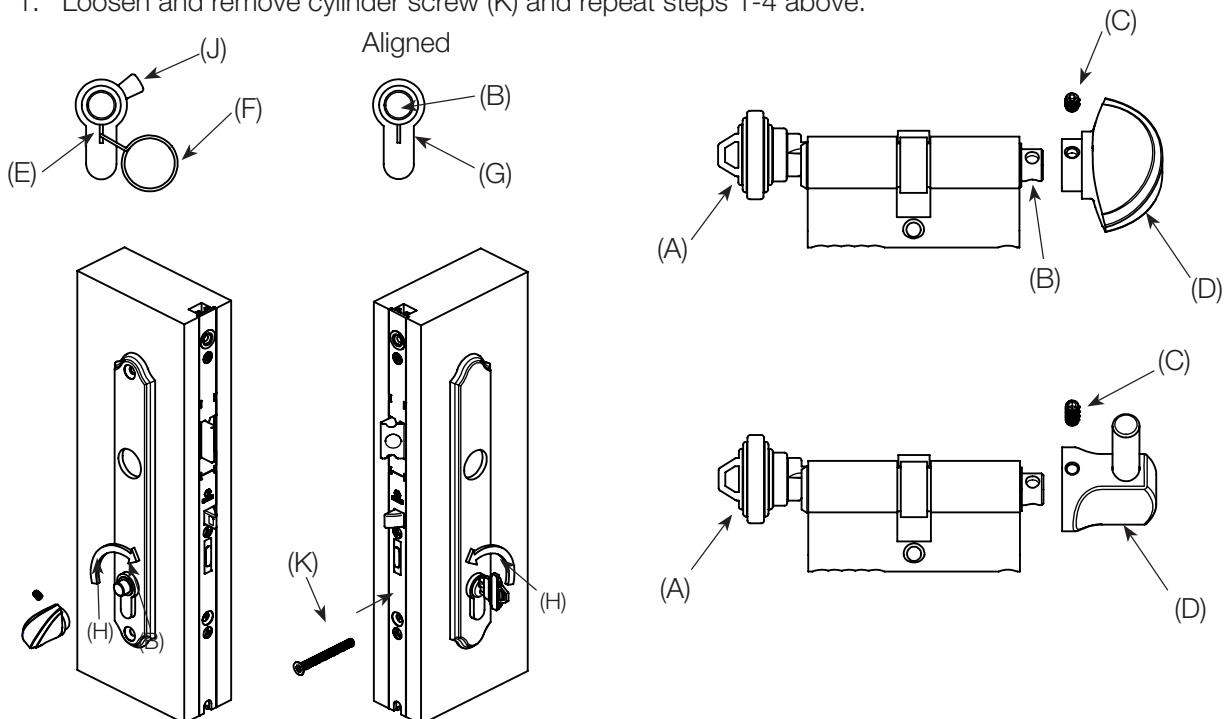

Swing Door Handle Operation Instructions

Handles and backplates vary in style.

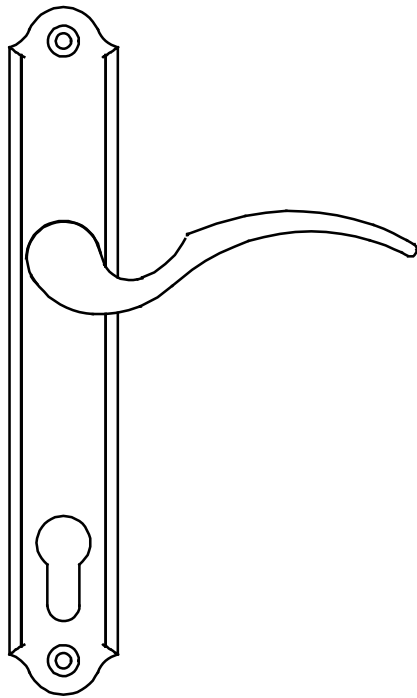

To lock automatic system, push door shut. Multipoint engages automatically.

To lock manual system, lift handle to engage multipoints prior to engaging deadbolt.

Use key or thumbturn to engage deadbolt.

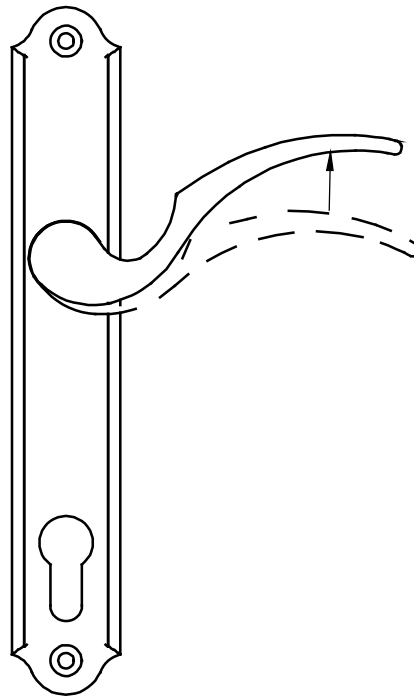

If deadbolt will not fully engaged, manually engage system by lifting handle prior to engaging deadbolt.

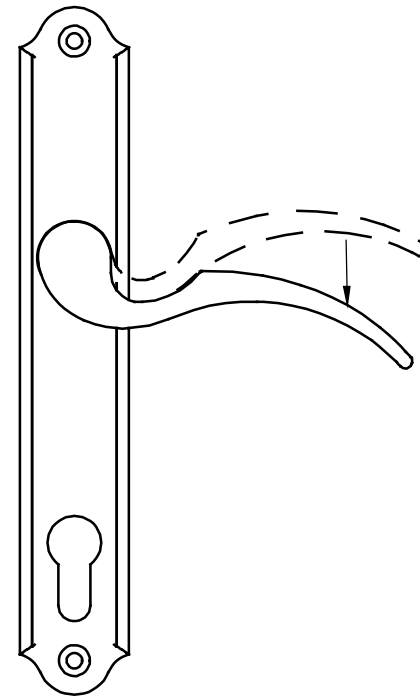

To open, disengage deadbolt with key or thumbturn, push handle down to stop and then open door.

HOPPE Profile Cylinders Rekeying Instructions



Handle of excellence.

Introduction

- Rekeying should be done by a qualified locksmith.
- Cylinder designs vary. HOPPE supplies CES brand cylinders and non-logo cylinders.
- Cylinders feature Schlage® SC1 keyways and may be rekeyed using Schlage® rekey kits.
- Cylinders should be rekeyed to an existing Schlage® key whenever possible.
- The HOPPE key gauge measures key cuts 1 through 9 the same as a Schlage® key gauge.
- If rekeying a CES cylinder with CES pins, use the CES pin number that corresponds with the measured key cut.
- If rekeying a CES cylinder with Schlage® pins, use the Schlage® pin number that is one less than the measured key cut. A key cut measuring 4 uses a #3 Schlage® pin.
- If rekeying a non-logo cylinder with Schlage® pins, then use the Schlage® pin number that corresponds with the measured key cut.
- If rekeying a non-logo cylinder with CES pins, use the CES pin number that is one higher than the measured key cut. A key cut measuring 4 uses a #5 CES pin.

Recommended Tools and Accessories



REMOVAL TOOL for PLASTIC INSERT
Part Number 2000899
(for use with CES cylinders)



2 mm or 5/64" HEX WRENCH
(for use with non-logo cylinders)

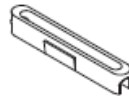

PLASTIC INSERT
Part Number 8771719
(for use with CES cylinders)

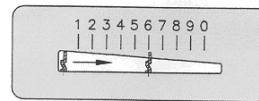

HOPPE KEY GAUGE
Part Number 2070820



HOPPE REKEY KITS
Schlage® Pins, 30 cyl. capacity
- Part Number 3459001
CES Pins, 10 cyl. capacity
- Part Number 8785243

Steps to Rekey

1.

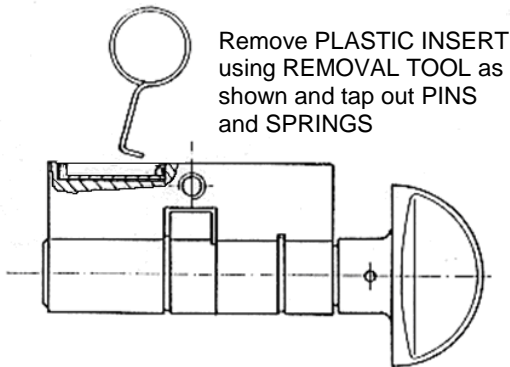

Remove PLASTIC INSERT using REMOVAL TOOL as shown and tap out PINS and SPRINGS

OR

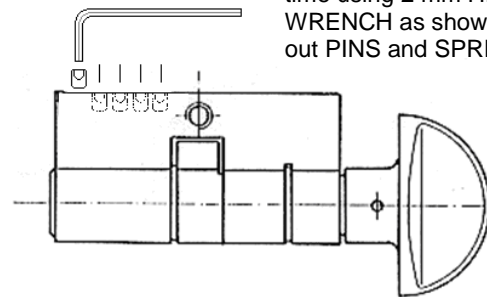

Remove one SET SCREW at a time using 2 mm HEX WRENCH as shown and tap out PINS and SPRING

2.

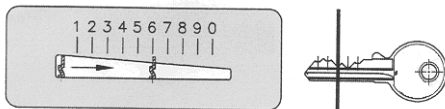

Determine CORE PIN size with KEYING GAUGE

3.

- Insert desired CORE PIN into the appropriate cylinder pin hole.
- Note: for cylinder designs featuring six pin holes, the innermost hole (furthest from the key face) is left blank.
- Insert HOUSING PIN
- Insert SPRING
- Repeat until all PINS have been replaced and install PLASTIC INSERT OR install SET SCREW and repeat until all PINS have been replaced.

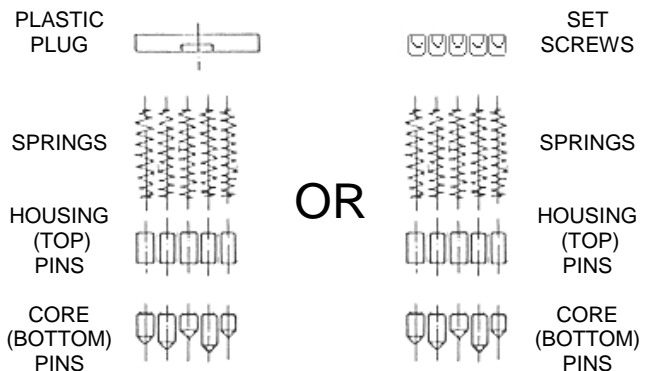

Handling of Keying Gauge

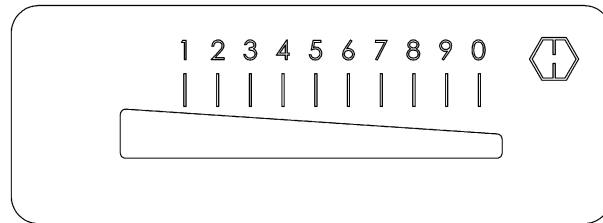

1. Move the key left into the gauge so the incisions show to the top.
2. Push the key within the incision to be measured to the right as far as possible.
3. Note the incision depth.

Note: HOPPE Gauge is for CES pins. If using Schlage pins the number will be (1) less.
Example: #5 CES pin is a #4 Schlage pin.

CES Pins VS. Schlage Pins Conversion Chart



It is possible to use either Schlage bottom (core) pins or CES bottom (core) pins when rekeying the Schlage “C” keyway cylinders, however, the pin lengths vary slightly between sources. The conversion chart below lists the correlation between CES and Schlage pin numbers and sizes.

Note: HOPPE gauge uses CES pin lengths. If using Schlage pins, the number will be (1) less. Example: #5 CES pin is a #4 Schlage pin.

<u>CES Pins</u>			<u>Schlage Pins</u>	
<u>Pin Length (mm)</u>	<u>Pin Number</u>	<u>Pin Length (inches)</u>	<u>Pin Number</u>	<u>Pin Length (inches)</u>
4.2	1	0.1654	0	0.1655
4.57	2	0.1799	1	0.1805
4.95	3	0.1949	2	0.1955
5.35	4	0.2106	3	0.2105
5.72	5	0.2252	4	0.2255
6.1	6	0.2402	5	0.2405
6.47	7	0.2547	6	0.2555
6.85	8	0.2697	7	0.2705
7.25	9	0.2854	8	0.2855
7.62	0	0.3000	9	0.3005